

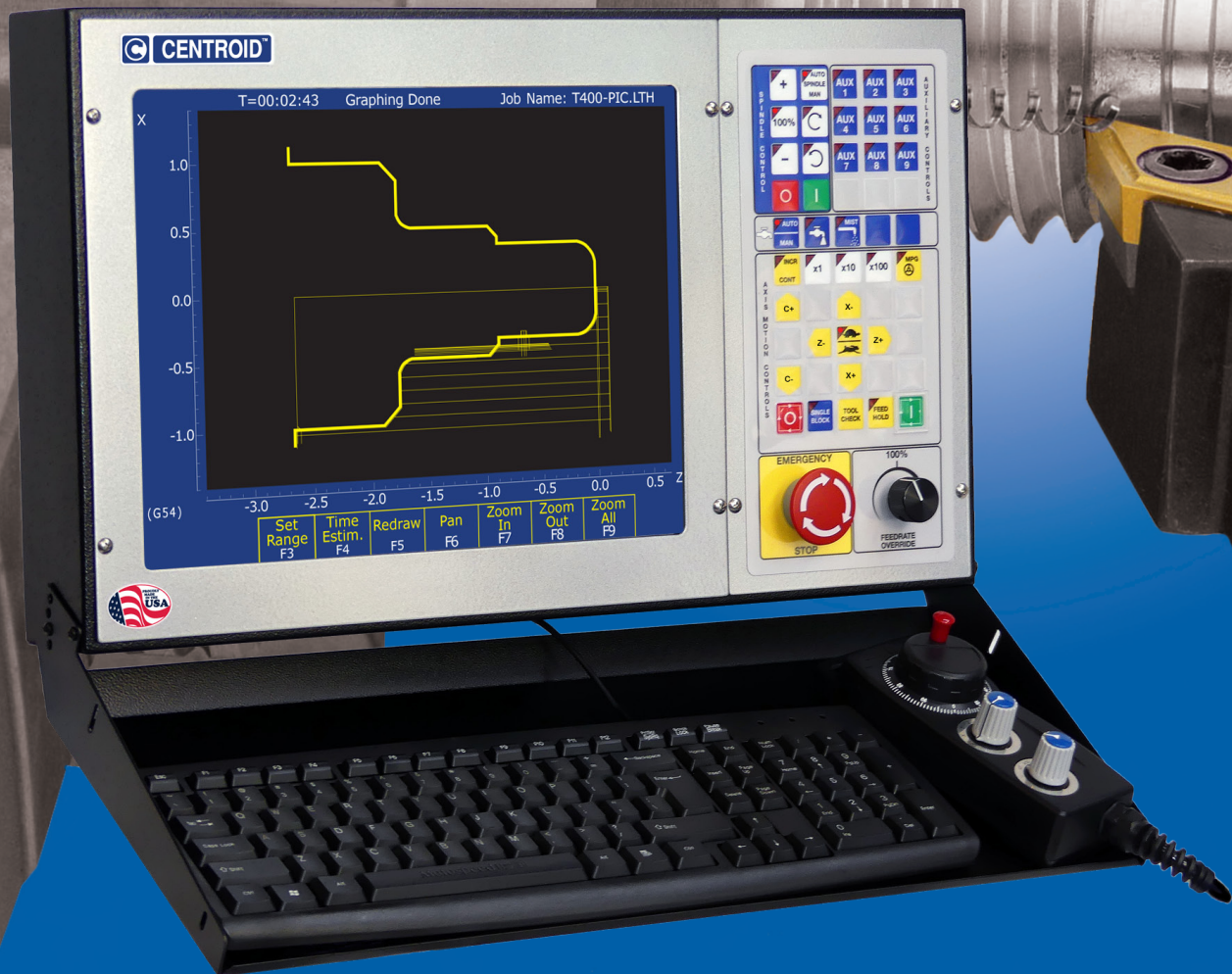

CENTROID™

T-400 CNC Control For Lathes

Do more with a CENTROID!



- Long product Life Cycle backed by affordable replacement CNC parts, repair, upgrades and support
- User-Friendly, Rock Solid, Factory Supported, Updateable Centroid CNC software
- Proven, Reliable CNC Software and CNC Hardware designed to work together
- Dedicated, Centroid manufactured Closed Loop CNC Motion Control CPU



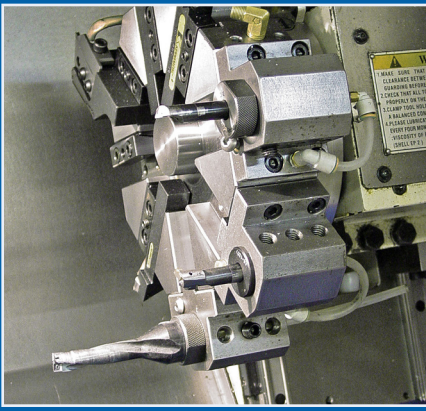

**ATC Turret Compatible
Electric or Hydraulic**

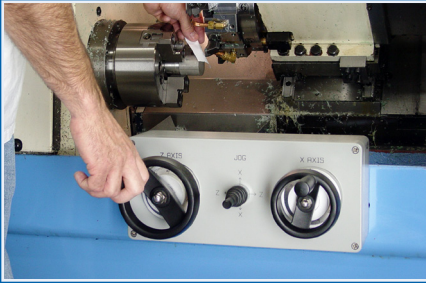

Dual Electronic Handwheels



Auto Tool Measurement

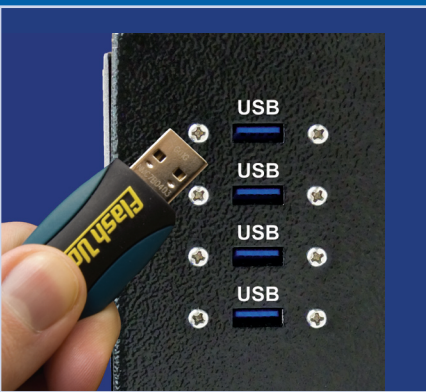

**Easy file transfer
w/ USB & LAN**

T-400 Options

- Dual Electronic Handwheels
- C-Axis
- Rigid Tapping
- MPG Handwheel
- Offline Conversational

Touch Screen LCD

Spindle control

**USB ports
LAN connection**

**Customizable
Auxiliary Keys**

**Remote Access
Support**

Coolant control

**Easy Dedicated
Operator
Interface**

Feedrate override

MPG handwheel*

Windows OS

Solid State Drive (SSD)

Do more with a CENTROID!

- Cut parts the first day with intuitive, straightforward CNC operation
- Increase profit and production with faster setups, easier programming, and reliable operation
- Expand machining capabilities and compete on higher paying jobs with affordable options
- Windows OS: Connect easily to any computer system by using USB, LAN, or Internet Remote access

Comprehensive CNC features :

- Compatible with electric or hydraulic tool turrets
- Compatible with hydraulic & air chucks, tailstocks
- Compatible with chip conveyors & bar feeders
- Compatible with dual electronic handwheels
- Tool life & tool wear offset adjustment menu
- "Tool Check": stop, measure, tweak offset & resume
- Front mount, rear mount, gang and live tooling
- Fill-in-the-blank part and tool setup menus
- Runs on industry standard G & M codes
- Built-in G code editor & G code backplot
- Compatible with popular CAD/CAM systems
- Dedicated Motion Control DSP CPU
- Reliable, no moving parts Solid State Drive (SSD)
- 15" Touch Screen LCD display
- Run 3rd party software of your choice
- Subprograms, multiple WCS and Macros
- One button push for common machine functions
- Spindle and Axis Load Meter display
- Digital servo drives, AC or DC servo motors
- Laser Ballscrew compensation
- Conversational with Teach mode
- Custom UI Screens for special applications
- Hand Held Electronic Handwheel option
- Remote Access support via internet connection

Constant Surface Speed Control

- Spindle speed automatically adjusts to provide the constant surface speed specified over the entire part
- Ensures steady tool load for consistent surface finish, proper chip creation and longer tool life
- Able to mix and match Feed per minute, Feed per revolution, combined with CSS or RPM within cycles
- Spindle encoder feedback for precise RPM or Constant Surface speed turning and Threading and Tapping

Run 3rd party software of your choice

- Install and operate most any CAD or CAD/CAM software directly on the Centroid CNC control
- Allows operator to use a CAD or CAD/CAM program to look up part dimensions, create and modify part programs
- Utilize CAD/CAM part turning simulation backplot and verification features directly at the control.
- Open CAD files directly on control via USB or LAN

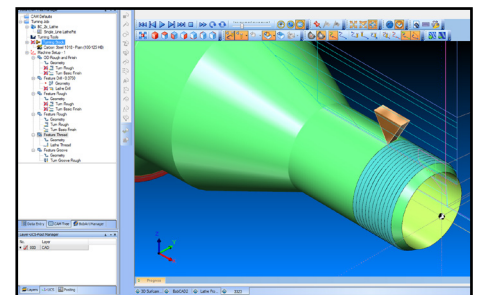

Make use of most any other windows compatible software or hardware in conjunction with the Centroid CNC control. Take advantage of useful and affordable tools such as: Skype, Teamviewer, G-code editors, Webcams, Microphones, Speakers, Wireless devices, backup Hard Drives, and much more.

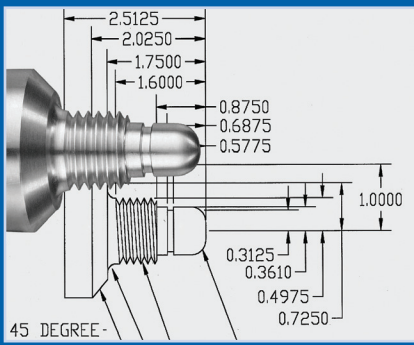

**From Print to Part...
in minutes!**

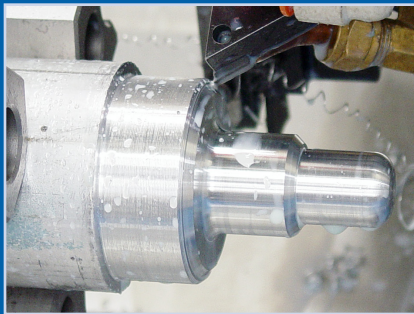

Automatic Profile Cleanout

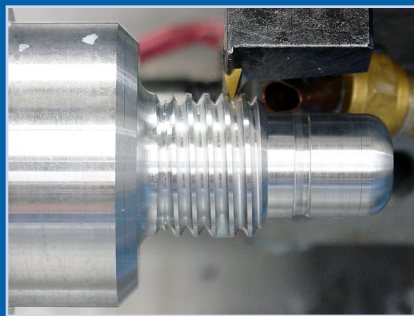

Smart Threading Cycles

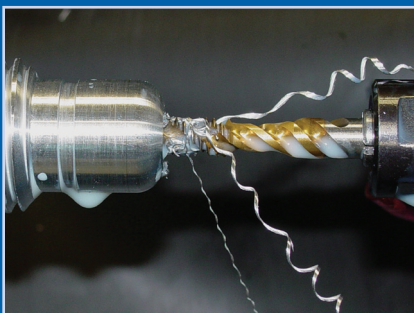

Drill, Bore, Tap*

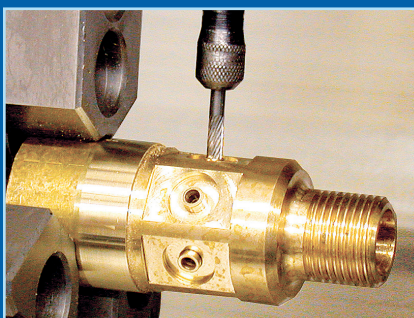

C axis & Live Tooling

Centroid's "Intercon" Conversational Programming

- Quickly create part programs right at the control
- Easy "fill-in-the-blank" canned cycles
- Graphical help menu and math assistance for missing dimensions and Teach mode
- Check your work instantly with tool path graphics
- No knowledge of G-codes necessary
- Smart Threading cycles w/ Thread Data Library
- Intercon automatically generates part G-code
- Seamless integration with cnc control software
- Offline version available for PC use

Part Program Tool Path Graphics, (aka G-code backplot)

- See a graphical preview of part while programming, graph at any point inside conversational
- See cutter compensated moves
- Preview and step through any part program before running the job
- Easily identify and correct over travel events
- Accurately estimate actual job runtime
- Stop and start the part graphics at any point
- Check G-code for errors before running the job
- Feedrate override knob controls graphing speed
- See feed rate and rapid rate moves
- Zoom in and pan to see detailed areas

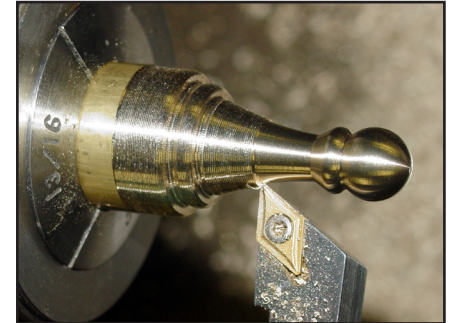
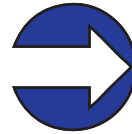
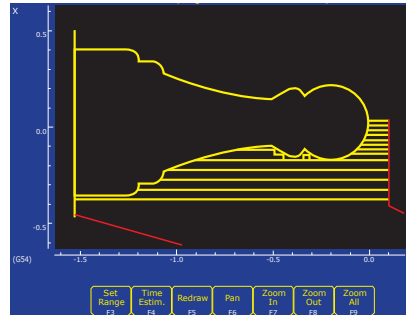

Automatic Profiling Cycle, Diameter or End Face

- Automatic profiling generates all the moves necessary to remove material from around the part profile.
- Enter only the finished part dimensions and material around the profile is automatically "roughed off"

Line and Arc Canned Cycles w/ auto Connect Radius and Teach Mode

- Program line moves with ease. Enter what you know: endpoint data, or taper angle and taper length
- Automatic connect radius for lines and arcs and automatic chamfer for lines
- Program Arcs with End Point & Radius, Center Point & Angle, Center Point & Endpoint or Three Points

Threading, Grooving, Turning, Cutoff, Chamfering, and Radius Cycles

- Canned threading cycles include: Inside, Outside, Compound, and Tapered (pipe) threading cycles
- Threading cycles can be used by simply selecting the thread from the built-in library or enter your own custom thread using type of thread and entering pitch, diameter, and length
- Designate threads Class with multi pass, spring pass, finish pass controls and multi lead threads
- Grooving: Straight, Chamfered, or Radiused Grooves on the inside, outside, front, or back of the part
- Turning: Diameter or End Face, ID or OD Turning, Straight or Angled, Rough and Finish passes

Canned Drill, Bore and Tapping Cycles

- Canned Drill and Bore cycles include: Peck Drill/Bore, Chip Breaking, Deep Hole Drill/Bore (chip removal), and Drill/Bore
- Use a tap to make threads with the canned Floating-tap or Rigid-tap cycle*
- Specify threads-per-inch, spindle speed, and depth and the control does the rest

Tapering Cycles

- Add any taper to your part, at any angle, by specifying a start and end point, or use the angle and length of the taper
- Intercon will automatically calculate any unknown values

C Axis Positioning*

- Used for contour milling and spindle positioning for drilling and tapping.
- Produce special profiles such as square sides, pockets, cams, and even lettering
- Provides accurate positioning around the circumference, on the face, or inside the part

*optional



One CNC Control for all your turning needs from Job Shops to Production rooms.



The T400 CNC control is suited to a wide variety of turning machine tools from:

- Precision Tool Room Lathes
- Job Shop Flat Bed Lathes
- Production Turning Centers
- Vertical Lathes
- and everything in between.

Customizable to match any CNC machine tool configuration or job requirement

Retrofit upgrades available for these popular machine tools: Hardinge, Mori Seiki, Fanuc, Anilam, Bridgeport, Prototrak, Ikegai, Bullard, Pratt & Whitney, Mazak, LeBlond, Berthiez, Warner Swasey, Cincinnati, Okuma, Daewoo, Star, Hitachi Seiki and more.

OEM, Pro Install or DIY CNC control systems for new installations or retrofit upgrades



- Pre-engineered CNC control packages are available for: Flat Bed Lathes, Slant Bed Lathes, Turning Centers, Vertical Lathes, Precision Hardinge Style Lathes, Gang Tooling Lathes and many other Turning related machine tools
- Common CNC control configurations are in stock and ready for immediate shipment
- Custom built to any machine tool specifications
- Retrofit upgrade kits for good machines with obsolete controls
- Ready-to-run CNC systems for new machine tools

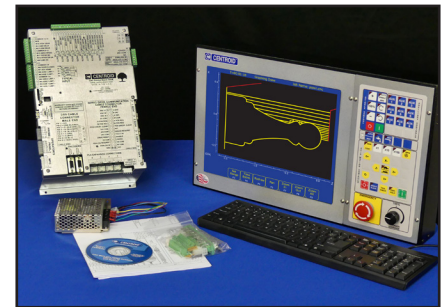

DIY CNC control kits

Ready to run pre-wired closed loop CNC systems with AC or DC Servo motors up to 8 axes, preconfigured I/O and pre-wired machine tool accessory cables customized to any machine tool.



Floor Stand



Arm Mount

Designed to last with over 37 years of experience

- CENTROID designs and manufactures its own state-of-the-art CNC control components. This allows us to provide the industry's most affordable replacement CNC parts and CNC support long after the sale.
- Low CENTROID CNC control operating costs increase your bottom line.
- CENTROID is a U.S. owned and operated company with thousands of CNC controls in operation worldwide.

Certified worldwide support

- Worldwide network of factory certified technicians provide fast and affordable CNC sales, training, service, installation and support.

Distributor:



CENTROID
 159 Gates Road • Howard, PA 16841
 Sales: (814) 353.9256 • Fax: (814) 353.9265
www.centroidcnc.com

Applies to standard export models:
 - Minimum programmable increment = .001mm
 - "Numerical control" units have three axis simultaneous contouring

*optional

• US Patent 6,490,500
 Copyright © 2012-2016 CENTROID 11-10-16 rev18